



# RCD-D Series

Downblast Centrifugal Roof Exhaust Fan



# Downblast Centrifugal Roof Exhaust Fan – RCD-D Series



RCD-D roof exhaust fan is designed for the removal of relative clean air from buildings. Typical applications include kitchen exhaust, laboratory fume exhaust and commercial building ventilation.

- A. Enclosed motor compartment isolates motor and drive from exhaust air.
- B. Aluminum alloy housing provides good appearance, light weight and weather resistance.
- C. Spun shroud structure provides maximum air performance.
- D. Non-overloading, backward inclined aluminum centrifugal wheel achieves high efficiency and minimum sound.
- E. All wheels are statically and dynamically balanced to AMCA 204-G2.5 standard.
- F. Reinforced guide vanes reduce turbulence and improve air performance.
- G. Totally enclosed motor, IP54 protection with class F insulation.
- H. Max air and fume stream temperature: 80°C.

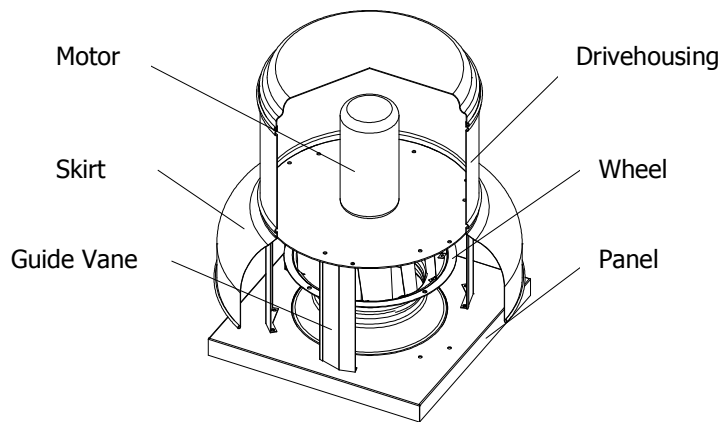

Dimension			
Model	ØA	B	□ C
RCD-D 315	800	730	610
RCD-D 355	800	740	610
RCD-D 400	926	822	710
RCD-D 450	926	862	710
RCD-D 500	1219	953	914
RCD-D 560	1219	993	914

All dimensions in mm

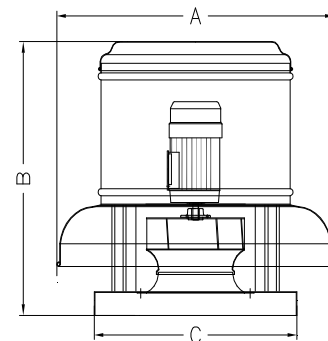

Technical Data – 50 Hz					
Model	Max. Q (m3/h)	Phase	N° Poles	Power kW	RPM
RCD-D 315 4P	2800	3	4	0.37	1340
RCD-D 315 6P	1900	3	6	0.37	885
RCD-D 355 4P	4100	3	4	0.55	1390
RCD-D 355 6P	2600	3	6	0.37	885
RCD-D 400 4P	5950	3	4	1.10	1390
RCD-D 400 6P	3800	3	6	0.37	885
RCD-D 450 4P	8550	3	4	2.20	1410
RCD-D 450 6P	5350	3	6	0.55	885
RCD-D 500 6P	8100	3	6	1.10	915
RCD-D 560 6P	11100	3	6	1.50	910

Technical Data – 60 Hz					
Model	Max. Q (m3/h)	Phase	N° Poles	Power kW	RPM
RCD-D 315 4P	3400	3	4	0.55	1610
RCD-D 315 6P	2250	3	6	0.37	1060
RCD-D 355 4P	4900	3	4	1.10	1670
RCD-D 355 6P	3100	3	6	0.37	1060
RCD-D 400 6P	4550	3	6	0.55	1060
RCD-D 450 6P	6650	3	6	1.10	1100
RCD-D 500 6P	9750	3	6	1.50	1100
RCD-D 560 6P	13800	3	6	3.00	1130

